

WebSTAR™

DOCSIS and Euro-DOCSIS Cable Modems



Model DPX100/120



Model DPX2100
Model EPX2100

Bringing the **Interactive**
Experience
Home™

WebSTAR™ Cable Modem User's Guide

Models DPX100, DPX120, DPX2100, and EPX2100

Introduction

Welcome to the exciting world of high-speed Internet access. Your new WebSTAR™ Cable Modem offers high-end performance and unsurpassed reliability. With your new WebSTAR Cable Modem, your Internet enjoyment and business productivity will surely soar.

This guide provides procedures and recommendations for placing, installing, configuring, operating, and troubleshooting your WebSTAR Cable Modem.

Benefits and Features

Your WebSTAR Cable Modem offers the following outstanding benefits and features:

- Provides a high-speed broadband Internet connection that energizes your online experience, and makes downloading and sharing files and photos with your family and friends hassle free
- Features Plug and Play operation for easy set up and installation
- Includes both USB and Ethernet connections
- Allows vertical or horizontal placement
- Allows automatic software upgrades by your cable service provider
- Ensures interoperability with most cable service providers by complying with Data Over Cable System Interface Specifications (DOCSIS)

In This Guide

Important Rules for Safe Operation	3
What's In the Carton?	6
Front Panel Description	7
Back Panel Description	8
Where is the Best Location for My Cable Modem?	9
What are the System Requirements for Internet Service?	9
How Do I Set Up My High-Speed Internet Access Account?	10
How Do I Connect My Devices to Use the Internet?	11
How Do I Configure TCP/IP Protocol?	13
How Do I Install USB Drivers?	16
Having Difficulty?	18
Tips for Improved Performance	20
How Do I Renew the IP Address on My PC?	21
Front Panel Status Indicator Functions	22
Notices	24
FCC Compliance	25
For Information	26

Important Rules for Safe Operation

Note to Installer

Note to CATV System Installer

This reminder is provided to call the CATV system installer's attention to Article 820-40 of the NEC (Section 54, Part I of the Canadian Electrical Code), that provides guidelines for proper grounding and, in particular, specifies that the CATV cable ground shall be connected to the grounding system of the building, as close to the point of cable entry as practical.

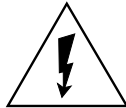

This symbol is intended to alert you that uninsulated voltage within this product may have sufficient magnitude to cause electric shock. Therefore, it is dangerous to make any kind of contact with any inside part of this product.



CAUTION: To reduce the risk of electric shock, do not remove cover (or back). No user-serviceable parts inside. Refer servicing to qualified service personnel.

WARNING
TO PREVENT FIRE OR ELECTRIC SHOCK, DO NOT EXPOSE THIS UNIT TO RAIN OR MOISTURE.



This symbol is intended to alert you of the presence of important operating and maintenance (servicing) instructions in the literature accompanying this product.

Read and Retain These Instructions

- Read all of the instructions before you operate this equipment. Give particular attention to all safety precautions. Retain the instructions for future reference.
- Comply with all warning and caution statements in the instructions. Observe all warning and caution symbols that are affixed to this equipment.
- Comply with all instructions that accompany this equipment.

Cleaning the Equipment

Before cleaning this equipment, unplug it from the electrical outlet. Use a damp cloth to clean this equipment. Do not use a liquid cleaner or an aerosol cleaner. Do not use a magnetic/static cleaning device (dust remover) to clean this equipment.

Placement

Place this equipment in a location that is close enough to an electrical outlet to accommodate the length of the power cord. Place this equipment on a stable surface. The surface must support the size and weight of this equipment. Place this equipment either horizontally or vertically.



WARNING:

Avoid personal injury and damage to this equipment. An unstable surface may cause this equipment to fall.

Accessories

Do not use accessories with this equipment unless recommended by your cable service provider.

Ventilation

This equipment has openings for ventilation that protect it from overheating. To ensure the reliability of this equipment, do not obstruct the openings.

- Do not place other equipment, lamps, books, or any other object on the top of or beside this equipment.
- Do not place this equipment in any of the locations that follow:
 - On a bed, sofa, rug, or similar surface
 - Over a radiator or a heat register
- In an enclosure, such as a bookcase or equipment rack, unless the installation provides proper ventilation

Overloading

Do not overload electrical outlets, extension cords, or integral convenience receptacles, as this can result in a risk of fire or electric shock. For equipment that requires battery power or other sources to operate, refer to the operating instructions for that equipment.

Object and Liquid Entry

Never push objects of any kind into this product through openings as they may touch dangerous voltage points or short out parts that could result in a fire or electric shock. Do not expose this equipment to liquid or moisture. Do not place this equipment on a wet surface. Do not spill liquids on or near this equipment.

Lightning and Power Surges

Plug your equipment into a surge protector in order to reduce the risk of damage from lightning strikes and power surges. If you are unsure of the type of surge protector to use, contact your cable service provider.

Servicing

Do not open the cover of this equipment. If you open the cover, your warranty will be void. Refer all servicing to qualified personnel only. Contact your cable service provider for instructions.

Power Cord Protection

Arrange all power cords so that people cannot walk on the cords, place objects on the cords, or place objects against the cords, which can damage the cords. Pay particular attention to cords that are at plugs, at electrical outlets, and at the places where the cords exit the equipment.

Power Sources

A label on the AC power adapter that is supplied with this equipment indicates the correct power source for this equipment. Operate this equipment only from an electrical outlet that has the voltage and frequency that the label indicates.

If you are unsure of the type of power supply to your residence, consult Scientific-Atlanta, Inc., or your local power company.

Grounding

This equipment may be provided with a three-prong plug. Properly ground (earth) this equipment by inserting the plug into a grounded electrical, three-socket outlet. If you are unable to insert this plug fully into the outlet, contact an electrician to replace your obsolete outlet.

Damage that Requires Service

For damage that requires service, unplug this equipment from the electrical outlet. Contact your cable service provider when any of the following situations occur:

- There is damage to the power cord or plug
- Liquid enters the equipment
- A heavy object falls on the equipment
- There is exposure to rain or water
- Operation is not normal (the instructions describe the proper operation)
- If you drop this equipment, or damage the cabinet of this equipment
- If this equipment exhibits a distinct change in performance

Upon completion of any service or repairs to this equipment (cable modem), ask the service technician to perform safety checks to determine that the equipment is in proper operating condition.

What's In the Carton?

When you receive your cable modem, you should check the equipment and accessories to verify that each item is in the carton and that each item is undamaged. The carton contains the following items, except as noted:



One Model DPX100/120 Cable Modem

or



One Model DPX2100 or EPX2100 Cable Modem



One Ethernet cable (CAT5/RJ-45)



One USB cable (not included with all models)



One power adapter with power cord (your power adapter may look slightly different, depending on your cable modem model)



One CD-ROM containing the user's guide and the USB drivers

If any of the items listed is missing or damaged, please contact SciCare™ Broadband Services at 1-800-722-2009 for assistance.

You will need an optional cable signal splitter and additional standard RF coaxial cable if you want to connect a VCR, a Digital Home Communications Terminal (DHCT) or a set-top converter, or a TV to the same cable connection as your cable modem.

Front Panel Description

The front panel of your cable modem provides status lights that indicate how well and at what state your cable modem is operating. After the cable modem is successfully registered on the network, the **POWER** and **CABLE** status indicators illuminate continuously to show that the cable modem is active and fully operational. See **Front Panel Status Indicator Functions**, later in this guide, for more information on front panel status indicator functions.

The following illustration and descriptions of the status indicators apply to the Model DPX100/120 Cable Modems along with the Model DPX2100 and Model EPX2100 Cable Modems.



Model DPX100/120 Cable Modems support DOCSIS 1.0 and 1.1 and Euro-DOCSIS 1.0 and 1.1, while Model DPX2100 and Model EPX2100 Cable Modems support DOCSIS 2.0.

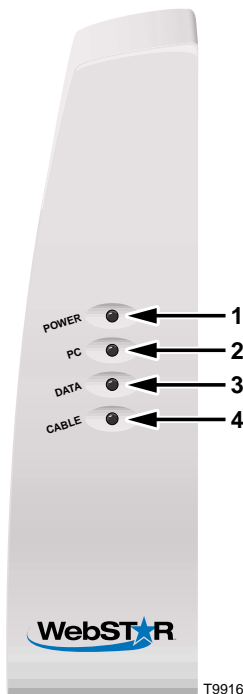

1. **POWER**—Illuminates solid green to indicate that power is being applied to the cable modem
2. **PC**—Illuminates solid green to indicate that an Ethernet/USB carrier is present and blinks to indicate that Ethernet/USB data is being transferred between the PC and the cable modem
3. **DATA**—Blinks to indicate that data is being transferred between the modem and the cable network
4. **CABLE**—Illuminates solid green when the modem is registered on the network and fully operational. This indicator blinks to indicate one of the following conditions:
 - The cable modem is booting up and not ready for data
 - The cable modem is scanning the network and attempting to register
 - The cable modem has lost registration on the network and will continue blinking until it registers again
 - Blinks very slowly (once every 5 seconds) to indicate that Cable Modem Access Protection is enabled
 - Blinks continuously to indicate that a Message is waiting

Back Panel Description

The following illustration describes the back panel components of the cable modem. The illustration and descriptions apply to the Model DPX100/120 Cable Modems along with Model DPX2100 and Model EPX2100 Cable Modems.

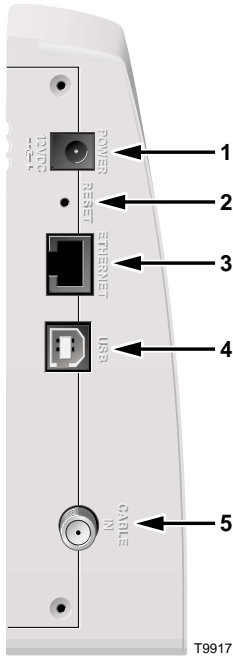

1. **POWER**—Connects the cable modem to the DC output of the AC power adapter that is provided with your cable modem. Only use the AC power adapter and power cord that is provided with your cable modem

2. **RESET**—Reset-to-Default button (Factory Reset)



This button is for maintenance purposes only. Do not use.

3. **ETHERNET**—RJ-45 Ethernet port connects to the Ethernet port on your PC

4. **USB**—12 Mbps USB port connects to the USB port on your PC

5. **CABLE IN**—F-Connector connects to an active cable signal from your cable service provider

Where is the Best Location for My Cable Modem?

The ideal location for your cable modem is where it has access to outlets and other devices. Think about the layout of your home or office, and consult with your cable service provider to select the best location for your cable modem.

Consider these recommendations:

- Position your PC and cable modem so that they are located near an AC power outlet.
- Position your PC and cable modem so that they are located near an existing cable input connection to eliminate the need for an additional cable outlet. There should be plenty of room to guide the cables away from the modem and the PC without straining or crimping them.
- Airflow around the cable modem should not be restricted.
- Choose a location that protects the cable modem from accidental disturbance or harm.
- Read this user's guide thoroughly before you decide where to place your cable modem.

What are the System Requirements for Internet Service?

To ensure that your cable modem operates efficiently for high-speed Internet service, verify that all of the Internet devices on your system meet or exceed the following minimum hardware and software requirements.



You will also need an active cable input line and an Internet connection.

Minimum System Requirements for PCs

- A PC with a Pentium MMX 133 processor or greater
- 32 MB of RAM
- Web browsing software (Netscape or Internet Explorer)
- CD-ROM drive

Minimum System Requirements for Macintosh

- MAC OS 7.5
- 32 MB of RAM

System Requirements for an Ethernet Connection

- A PC with Windows 95 operating system (or later) with TCP/IP protocol installed, or an Apple Macintosh computer with TCP/IP protocol installed
- An active 10/100BaseT Ethernet network interface card (NIC) installed in your PC

System Requirements for a USB Connection

- A PC with a Windows /98SE/ME/2000 or XP operating system
- A master USB port installed in your PC

How Do I Set Up My High-Speed Internet Access Account?

Before you can use your cable modem, you need to have a high-speed Internet access account. If you do not have a high-speed Internet access account, you need to set up a high-speed Internet access account with your local cable service provider. Choose *one* of the following two options.

I Do Not Have a High-Speed Internet Access Account

If you do *not* have a high-speed Internet access account, your cable service provider will set up your high-speed Internet access account and become your Internet Service Provider (ISP). Internet access enables you to send and receive e-mail, access the World Wide Web, and receive other Internet services. When you contact your cable service provider, they will ask you for the serial number and Media Access Control (MAC) address of the cable modem.

These numbers appear on a bar code label located on the side of the cable modem. The serial number consists of a series of alphanumeric characters preceded by **S/N**. The MAC address consists of a series of alphanumeric characters preceded by **MAC**.

Write down these numbers in the space provided here.

Serial Number _____
MAC Address _____

The following illustration shows a sample bar code label.

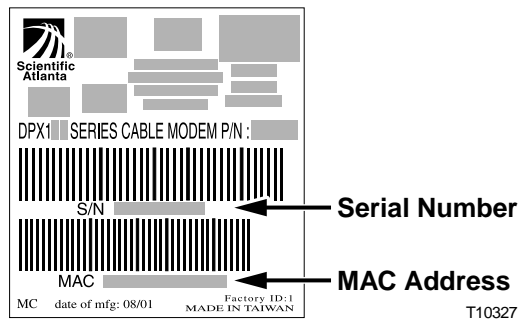

I Already Have an Existing High-Speed Internet Access Account

If you have an existing high-speed Internet access account, you must give your cable service provider the serial number and the MAC address of the cable modem. Refer to the serial number and MAC address information listed previously in this section.



You may be able to continue to use your existing e-mail account with your cable modem. Contact your cable service provider for more information.

How Do I Connect My Devices to Use the Internet?

You can use your cable modem to access the Internet, and you can share that Internet connection with other Internet devices in your home or office. Sharing one connection among many devices is called networking.

Connecting and Installing Internet Devices

You must connect and install your cable modem to access the Internet. Professional installation may be available. Contact your local cable service provider for further assistance.

To connect devices

The following diagram illustrates one of the various Internet connection options that are available to you.

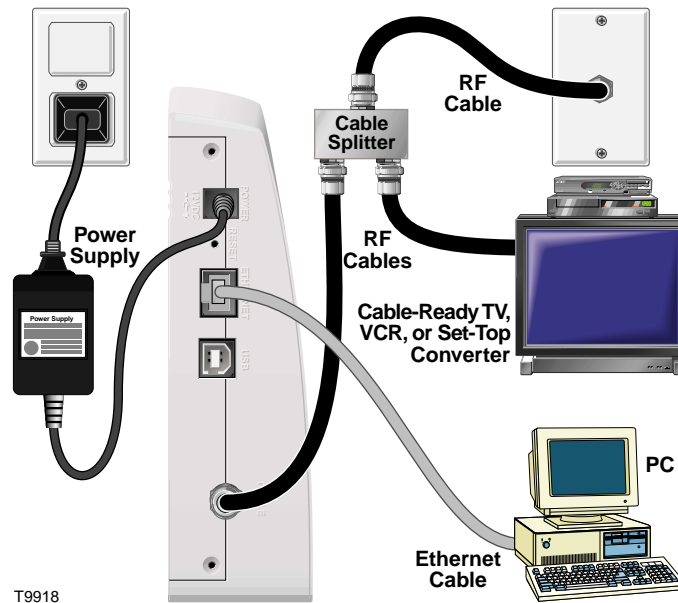

 **WARNING:**
To avoid personal injury or damage to your equipment, follow these steps in the exact order shown.

To install the cable modem

1. Power down your PC and unplug it from the power source.
2. Connect your PC to *either* the **Ethernet** port *or* the **USB** port using the appropriate data cable. Do not connect your PC to *both* the Ethernet and USB ports at the same time. You *can* connect two separate PCs to the cable modem at the same time by connecting one PC to the Ethernet port and one PC to the USB port.
3. Insert the AC power adapter cord into the DC power connector on the back of the cable modem, and then plug the power adapter into an AC power source.
4. Connect the active RF coaxial cable to the **CABLE IN** connector. Use an optional cable signal splitter to add a TV, a DHCT or set-top converter, or a VCR.
5. Plug in and power on your PC.
6. The cable modem will then begin an automatic search to locate and sign on to the broadband data network. This process may take up to 5 minutes. The modem will be ready for use when the **CABLE** indicator on the front panel stops blinking and illuminates continuously.
7. The next step in setting up your cable modem is to configure your Internet devices for Internet access. Choose one of the following options:
 - If you want to use Ethernet connections, you must configure the TCP/IP protocol. To configure the TCP/IP protocol go to **How Do I Configure TCP/IP Protocol?**, next in this guide.
 - If you want to use USB connections, you must install the USB drivers. To install the USB Drivers for USB go to **How Do I Install USB Drivers?**, later in this guide.

How Do I Configure TCP/IP Protocol?

To configure TCP/IP protocol, you need to have an Ethernet Network Interface Card (NIC) with TCP/IP communications protocol installed on your system. TCP/IP is a communications protocol used to access the Internet. This section contains instructions for configuring TCP/IP on your Internet devices to operate with the cable modem in Windows or Macintosh environments.

Configuring TCP/IP on Your Internet Devices

TCP/IP protocol in a Windows environment is different for each Windows version. Follow the appropriate instructions in this section for your operating system.

To configure Windows 95/98/98SE/ME systems

1. Click **Start**, select **Settings**, and choose **Control Panel**.
2. Double-click the **Network** icon in the Control Panel window.
3. Read the list of installed network components under the **Configuration** tab to verify that your PC contains the TCP/IP protocol.
4. Is TCP/IP protocol listed in the installed network components list?
 - If **yes**, go to step 7.
 - If **no**, click **Add**, click **Protocol**, click **Add**, and then go to step 5.
5. Click **Microsoft** in the Manufacturers list.
6. Click **TCP/IP** in the Network Protocols list, and then click **OK**.
7. Click the **TCP/IP Ethernet Adapter** protocol, and then choose **Properties**.
8. Click the IP Address tab, and then select **Obtain an IP address automatically**.
9. Click the **Gateway** tab and verify that these fields are empty. If they are not empty, highlight and delete all information from the fields.
10. Click the **DNS Configuration** tab, and then select **Disable DNS**.
11. Click **OK**.
12. Click **OK** when the system finishes copying the files, and then close all networking windows.
13. Click **YES** to restart your computer when the System Settings Change dialog box opens. The computer restarts. The TCP/IP protocol is now configured on your PC and your Ethernet devices are ready for use.
14. Try to access the Internet. If you cannot access the Internet, go to **Having Difficulty?**, later in this guide. If you still cannot access the Internet, contact your cable service provider for further assistance.

To configure Windows 2000 systems

1. Click **Start**, select **Settings**, and choose **Network and Dial-up Connections**.
2. Double-click the **Local Area Connection** icon in the Network and Dial-up Connections window.
3. Click **Properties** in the Local Area Connection Status window.
4. Click **Internet Protocol (TCP/IP)** in the Local Area Connection Properties window, and then click **Properties**.
5. Select *both* **Obtain an IP address automatically** and **Obtain DNS server address automatically** in the Internet Protocol (TCP/IP) Properties window, and then click **OK**.
6. Click **Yes** to restart your computer when the Local Network window opens. The computer restarts. The TCP/IP protocol is now configured on your PC and your Ethernet devices are ready for use.
7. Try to access the Internet. If you cannot access the Internet, go to **Having Difficulty?**, later in this guide. If you still cannot access the Internet, contact your cable service provider for further assistance.

To configure Windows XP systems

1. Click **Start**, select **Connect to**, and choose **Show all connections**.
2. Double-click the **Local Area Connection** icon in the **LAN or High-Speed Internet** section of the Network Connections window.
3. Click **Properties** in the Local Area Connection Status window.
4. Click **Internet Protocol (TCP/IP)**, and then click **Properties** in the Local Area Connection Properties window.
5. Select *both* **Obtain an IP address automatically** and **Obtain DNS server address automatically** in the Internet Protocol (TCP/IP) Properties window, and then click **OK**.
6. Click **Yes** to restart your computer when the Local Network window opens. The computer restarts. The TCP/IP protocol is now configured on your PC and your Ethernet devices are ready for use.
7. Try to access the Internet. If you cannot access the Internet, go to **Having Difficulty?**, later in this guide. If you still cannot access the Internet, contact your cable service provider for further assistance.

To configure Macintosh systems

1. Click the **Apple** icon in the upper left corner of the Finder. Scroll down to **Control Panels**, and then click **TCP/IP**.
2. Click **Edit** on the Finder (gray bar) at the top of the screen. Scroll down to the bottom of the menu, and then click **User Mode**.
3. Click **Advanced** in the User Mode window, and then click **OK**.
4. Click the **Up/Down** selector arrows located to the right of the Connect Via section of the TCP/IP window, and then click **Using DHCP Server**.
5. Click **Options** in the TCP/IP window, and then click **Active** in the TCP/IP Options window.

Note: In some cases, the **Load only when needed** option will not appear. If it appears, select the option. A check mark appears in the option.

6. Verify that the **Use 802.3** option located in the upper right-hand corner of the TCP/IP window is unchecked. If there is a check mark in the option, deselect the option, and then click **Info** in the lower left corner.
7. Is there a Hardware Address listed in this window?
 - If **yes**, click **OK**. To close the **TCP/IP Control Panel** window, click **File**, and then scroll down to click **Close**. You have completed this procedure.
 - If **no**, you must power off your Macintosh.
8. With the power off, simultaneously press and hold down the **Command (Apple)**, **Option**, **P**, and **R** keys on your keyboard. Keeping those keys pressed down, power on your Macintosh but do not release these keys until you hear the Apple chime.
9. Continue pressing these keys for up to three chimes, then release the keys and allow the computer to restart.
10. When your computer fully reboots, repeat steps 1 through 7 to verify that all TCP/IP settings are correct. If your computer *still* does not have a Hardware Address, contact your authorized Apple dealer or Apple technical support center for further assistance.

How Do I Install USB Drivers?

To install USB drivers, your PC must be equipped with a USB network interface and a Windows 98SE/ME/2000/XP operating system. This section contains instructions for installing the cable modem gateway USB drivers.



If you are not using the USB interface, skip this section.

Installing USB Drivers

The USB driver installation procedures are different for each operating system. Follow the appropriate instructions in this section for your operating system.

To install Windows 98SE and Windows ME USB drivers

1. Insert the **USB Cable Modem Driver Installation Disk** into the CD-ROM drive of your PC.
2. Wait until the **Power** and **Cable** indicators on the cable modem illuminate solid green.
Result: The Add New Hardware Wizard window opens.
3. Click **Next** in the Add New Hardware Wizard window.
4. Select **Search for the best driver for your device (Recommended)** in the Add New Hardware Wizard window, and then click **Next**.
5. Select **CD-ROM drive** in the Add New Hardware Wizard window, and then click **Next**.
6. Select **The updated driver (Recommended)** in the Add New Hardware Wizard window, and then click **Next**.
7. Click **Next** in the Add New Hardware Wizard window. The Copying Files window opens. After 10 to 20 seconds have passed, the Add New Hardware Wizard window reopens.
8. Click **Finish**. The USB driver installation is complete.
9. Click **Yes** in the System Settings Change window to restart your computer. The computer restarts. The USB drivers are now installed on your PC and your USB devices are ready for use.
10. Try to access the Internet. If you cannot access the Internet, go to **Having Difficulty?**, next in this guide. If you still cannot access the Internet, contact your cable service provider for further assistance.

To install Windows 2000 drivers

1. Insert the **USB Cable Modem Driver Installation Disk** into the CD-ROM drive of your PC.
2. Wait until the **Power** and **Cable** indicators on the cable modem illuminate solid green.
3. Click **Next** in the Found New Hardware Wizard window.
4. Select **Search for a suitable driver for my device (recommended)** in the Found New Hardware Wizard window, and then click **Next**.
5. Select **CD-ROM drives** in the Found New Hardware Wizard window, and then click **Next**.
6. Click **Next** in the Found New Hardware Wizard window. The system searches for the driver file for your hardware device.
7. After the system finds the USB driver, the Digital Signature Not Found window opens displaying a confirmation message to continue the installation.
8. Click **Yes** to continue the installation. The Found New Hardware Wizard window reopens with a message that the installation is complete.
9. Click **Finish** to close the Found New Hardware Wizard window. The USB drivers are installed on your PC and your USB devices are ready for use.
10. Try to access the Internet. If you cannot access the Internet, go to **Having Difficulty?**, next in this guide. If you still cannot access the Internet, contact your cable service provider for further assistance.

To install Windows XP drivers

1. Insert the **USB Cable Modem Driver Installation Disk** into the CD-ROM drive of your PC.
2. Wait until the **Power** and **Cable** indicators on the cable modem illuminate solid green.
3. Select **Install from a list or specific location (Advanced)** in the Found New Hardware Wizard window, and then click **Next**.
4. Select **Search removable media (floppy, CD-ROM)** in the Found New Hardware Wizard window, and then click **Next**.
5. Click **Continue Anyway** in the Hardware Installation window to continue the installation. The Found New Hardware Wizard window reopens with a message that the installation has finished.
6. Click **Finish** to close the Found New Hardware Wizard window. The USB drivers are installed on your PC and your USB devices are ready for use.
7. Try to access the Internet. If you cannot access the Internet, go to **Having Difficulty?**, next in this guide. If you still cannot access the Internet, contact your cable service provider for further assistance.

Having Difficulty?

Frequently Asked Questions

Q. What if I don't subscribe to cable TV?

A. If cable TV is available in your area, data service may be made available with or without subscribing to cable TV service. Contact your local cable service provider for complete information on cable services, including high-speed Internet access.

Q. How do I arrange for installation?

A. Professional installation from your cable service provider may be provided. A professional installation ensures proper cable connection to the modem and to your PC, and ensures proper configuration of all hardware and software settings. Contact your cable service provider for more information about installation.

Q. How does the WebSTAR Cable Modem connect to my computer?

A. The cable modem connects to the USB port or the 10/100BaseT Ethernet port on your PC. If your PC is not equipped with an Ethernet interface, an Ethernet card is available from your local PC or office supply retailer, or from your cable service provider.

Q. After my cable modem is connected, how do I access the Internet?

A. Your local cable service provider becomes your Internet Service Provider (ISP), offering a wide range of services including e-mail, chat, news, and information services. Your cable service provider will provide the software you will need.

Q. Can I watch TV and surf the Internet at the same time?

A. Absolutely! If you subscribe to cable television service, you can watch TV and use your cable modem at the same time by connecting your TV and your cable modem to the cable network using an optional cable signal splitter.

Q. Can I run more than one device on the modem?

A. Yes—a single WebSTAR cable modem will support up to 31 Ethernet devices utilizing a user-supplied Ethernet hub that you can purchase at your local PC or office supply retailer. Another user at your location can simultaneously connect to the USB port on the cable modem. Contact your cable service provider for further assistance.

Common Troubleshooting Issues

I don't understand the front panel status indicators.

See **Front Panel Status Indicator Functions**, later in this guide for more detailed information on the front panel status indicator operation and function.

The modem does not register an Ethernet connection.

- Verify that your computer has a 10/100BaseT Ethernet card and that the Ethernet driver software is properly installed. If you purchase and install an Ethernet card, follow the installation instructions very carefully.
- Verify the status of the front panel status indicator lights.

The modem does not register an Ethernet connection after connecting to a hub.

If you are connecting multiple PCs to the cable modem, you should first connect the modem to the up-link port of the hub. The **LINK** LED of the hub will illuminate continuously.

The modem does not register a cable connection.

- The modem works with a standard 75-ohm RF coaxial cable. If you are using a different cable, your cable modem will not function properly. Contact your cable service provider to determine whether you are using the correct cable.
- Verify that you have followed the procedure in **How Do I Renew the IP address for Windows 95/98/98SE and ME PCs?**, later in this guide.
- Your NIC card or USB interface may be malfunctioning. Refer to the troubleshooting information in the NIC or USB documentation.

Tips for Improved Performance

Check and Correct

If your cable modem does not perform as expected, the following tips may help. If you need further assistance, contact your cable service provider.

- Verify that the plug to your cable modem AC adapter is properly inserted into an electrical outlet.
- Verify that your cable modem AC adapter is *not* plugged into an electrical outlet that is controlled by a wall switch. If a wall switch controls the electrical outlet, make sure the switch is in the **ON** position.
- Verify that the **Power** and **Cable** indicators on the front panel of your cable modem are illuminated.
- Verify that all cables are properly connected, and that you are using the correct cables.
- Verify that your cable service is active and that it supports two-way service.
- Verify that your TCP/IP is properly installed and configured if you are using the Ethernet connection.
- Verify that you have followed the procedures in **How Do I Install the USB Drivers?**, earlier in this guide, if you are using the USB connection.
- Verify that you have called your cable service provider and given them the serial number and MAC address of your cable modem.
- If you are using a cable signal splitter so that you can connect the cable modem to other devices, remove the splitter and reconnect the cables so that the cable modem is connected directly to the cable input. If the cable modem now functions properly, the cable signal splitter may be defective and may need to be replaced.

How Do I Renew the IP Address on My PC?

If your PC cannot access the Internet after the cable modem is online, it is possible that your PC did not renew its IP address.

Renewing the IP Address on Your PC

Follow the appropriate instructions in this section for your operating system to renew the IP address on your PC.

To renew the IP address for Windows 95/98/98SE/ME systems

1. Click **Start**, and then click **Run** to open the Run window.
2. Type **winipcfg** in the Open field, and click **OK** to execute the winipcfg command. The IP Configuration window opens.
3. Click the down arrow to the right of the top field, and select the Ethernet adapter that is installed on your PC. The IP Configuration window displays the Ethernet adapter information.
4. Click **Release**, and then click **Renew**. The IP Configuration window displays a new IP address.
5. Click **OK** to close the IP Configuration window, you have completed this procedure.



If you cannot access the Internet, contact your cable service provider for further assistance.

To renew the IP address for Windows 2000/NT/XP systems

1. Open a Command Prompt (DOS) window.
2. At the C:/ prompt, type **ipconfig/release** and press **Enter**. The system releases the IP address.
3. At the C:/ prompt, type **ipconfig/renew** and press **Enter**. The system displays a new IP address.
4. To close the Command Prompt window, click on the **X** in the upper right corner of the window. You have completed this procedure.



If you cannot access the Internet, contact your cable service provider for further assistance.

Front Panel Status Indicator Functions

Initial Power Up, Calibration, and Registration

The following chart illustrates the sequence of steps and the corresponding appearance of the cable modem front panel status indicators during power up, calibration, and registration on the network. Use this chart to troubleshoot the power up, calibration, and registration process of your cable modem.



After the cable modem completes step 8 (Registration Completed), the modem proceeds immediately to step 9, Normal Operations.

Front Panel LED Status Indicators During Initial Power Up, Calibration, and Registration							
Step →	1	2	3	4	5	6	7
Front Panel Indicator	Self Test	Downstream Scan	Downstream Signal Lock	Ranging	Requesting IP Address	Registering	Registration Completed
1	POWER	ON	ON	ON	ON	ON	ON
2	PC	ON	ON or BLINKING	ON or BLINKING	ON or BLINKING	ON or BLINKING	ON
3	DATA	ON	OFF	OFF	OCCASIONAL BLINKING	OCCASIONAL BLINKING	OCCASIONAL BLINKING
4	CABLE	ON	SLOW BLINKING 1 blink	MOMENTARY ON	OFF	BLINKING 2 blinks	BLINKING 4 blinks

T10530

Normal Operations

The following chart illustrates the appearance of the cable modem front panel LED status indicators during normal operations.

Front Panel LED Status Indicators During Normal Operations	
Step	8
Front Panel Indicator	Normal Operations (Bold denotes normal)
1	POWER ON
2	PC ON - When a single device is connected to either the Ethernet or USB port and no data is being sent to or from the modem. BLINKS - LED blinks when only one Ethernet or USB device is connected and data is being transferred between the consumer premise equipment (CPE) and the cable modem. OFF - When no devices are connected to either the Ethernet or USB ports. Note: With both Ethernet and USB devices connected to the modem at the same time, when data is being transferred through only one of the devices (Ethernet or USB), the indicator will illuminate continuously. Whenever data is being sent through both data ports (Ethernet and USB) simultaneously, the indicator will blink as described above.
3	DATA BLINKS - To indicate data is being transferred between the modem and the network.
4	CABLE ON

T10531

Special Conditions

The following chart describes the appearance of the cable modem front panel status indicators during special conditions to show that cable modem access protection is enabled, or that you have been denied network access.

Front Panel Indicators During Special Conditions				
Front Panel Indicator		Cable Modem Access Protection Enabled	Network Access Denied	Message Waiting Indicator
1	POWER	OFF	SLOW BLINKING 1 time per second	ON
2	PC	OFF	SLOW BLINKING 1 time per second	ON or BLINKING
3	DATA	OFF	SLOW BLINKING 1 time per second	OCCASIONAL BLINKING
4	CABLE	VERY SLOW BLINKING 1 time every 5 seconds	SLOW BLINKING 1 time per second	CONTINUOUS BLINKING

T10243

Notices

Trademarks

Scientific-Atlanta and the Scientific-Atlanta ARCs logo are registered trademarks of Scientific-Atlanta, Inc. WebSTAR and "Bringing the Interactive Experience Home" are trademarks of Scientific-Atlanta, Inc.

Other trademarks listed herein are the property of their respective owners.

Disclaimer

Scientific-Atlanta, Inc. assumes no responsibility for errors or omissions that may appear in this guide. Scientific-Atlanta reserves the right to change this guide at any time without notice.

Documentation Copyright Notice

© 2003 Scientific-Atlanta, Inc. All rights reserved.
Printed in the United States of America.

Information in this document is subject to change without notice. No part of this document may be reproduced in any form without the express written permission of Scientific-Atlanta, Inc.

Software Use Notice

The software described in this document is copyrighted and furnished to you under a license agreement. You may only use or copy this software in accordance with the terms of your license agreement.

Firmware Use Notice

The firmware in this equipment is copyrighted. You may only use the firmware in the equipment in which it is provided. Any reproduction or distribution of this firmware, or any portion of it, without express written consent is prohibited.

FCC Compliance

United States FCC Compliance

This equipment has been tested and found to comply with the applicable limits of Part 15 of FCC Rules. These limits are designed to provide reasonable protection against harmful interference in a residential installation. This equipment generates, uses, and can radiate radio frequency energy and, if not installed and used in accordance with the instructions, may cause harmful interference to radio or TV reception, which can be determined by turning the equipment off and on. The user is encouraged to try to correct the interference by one or more of the following measures:

- Increase the separation between the equipment and receiver
- Connect the equipment into an outlet on a circuit different from that to which the receiver is connected
- Consult your cable company or an experienced radio/TV technician for help

Any changes or modifications not expressly approved by Scientific-Atlanta could void the user's authority to operate the equipment.

The information shown in the FCC Declaration of Conformity paragraph below is a requirement of the FCC and is intended to supply you with information regarding the FCC approval of this device. *The phone numbers listed are for FCC-related questions only and not intended for questions regarding the connection or operation for this device. Please contact your cable service provider for any questions you may have regarding the operation or installation of this device.*

FCC Declaration of Conformity

This device complies with *Part 15 of FCC Rules*. Operation is subject to the following two conditions: 1) the device may not cause harmful interference, and 2) the device must accept any interference received, including interference that may cause undesired operation.

WebSTAR Cable Modem
Model DPX100/120
Model DPX2100
Model EPX2100
Scientific-Atlanta, Inc.
5030 Sugarloaf Parkway
Lawrenceville, Georgia 30044 USA
Telephone: **770-236-1077**

Canada EMI Regulation

This Class B digital apparatus meets all requirements of the Canadian Interference Causing Equipment Regulations.

Cet appareil numérique de la classe B respecte toutes les exigences du Règlement sur le matériel brouilleur du Canada.

For Information

If You Have Questions

If you have technical questions, contact your local cable service provider.



**Scientific
Atlanta**

Bringing the Interactive
Experience Home

Scientific-Atlanta, Inc.
770.236.5000

5030 Sugarloaf Parkway, Box 565447

Lawrenceville, GA 30042
www.scientificatlanta.com

Scientific-Atlanta and the Scientific-Atlanta logo are registered trademarks of Scientific-Atlanta, Inc. "Bringing the Interactive Experience Home" and WebSTAR are trademarks of Scientific-Atlanta, Inc. All other trademarks shown are trademarks of their respective owners.

Product and service availability subject to change without notice.

© 2003 Scientific-Atlanta, Inc. All rights reserved.
February 2003 Printed in USA

Part Number 749610 Rev B